

E1203H SERIES

1.20mm PITCH WIRE TO BOARD CONNECTOR

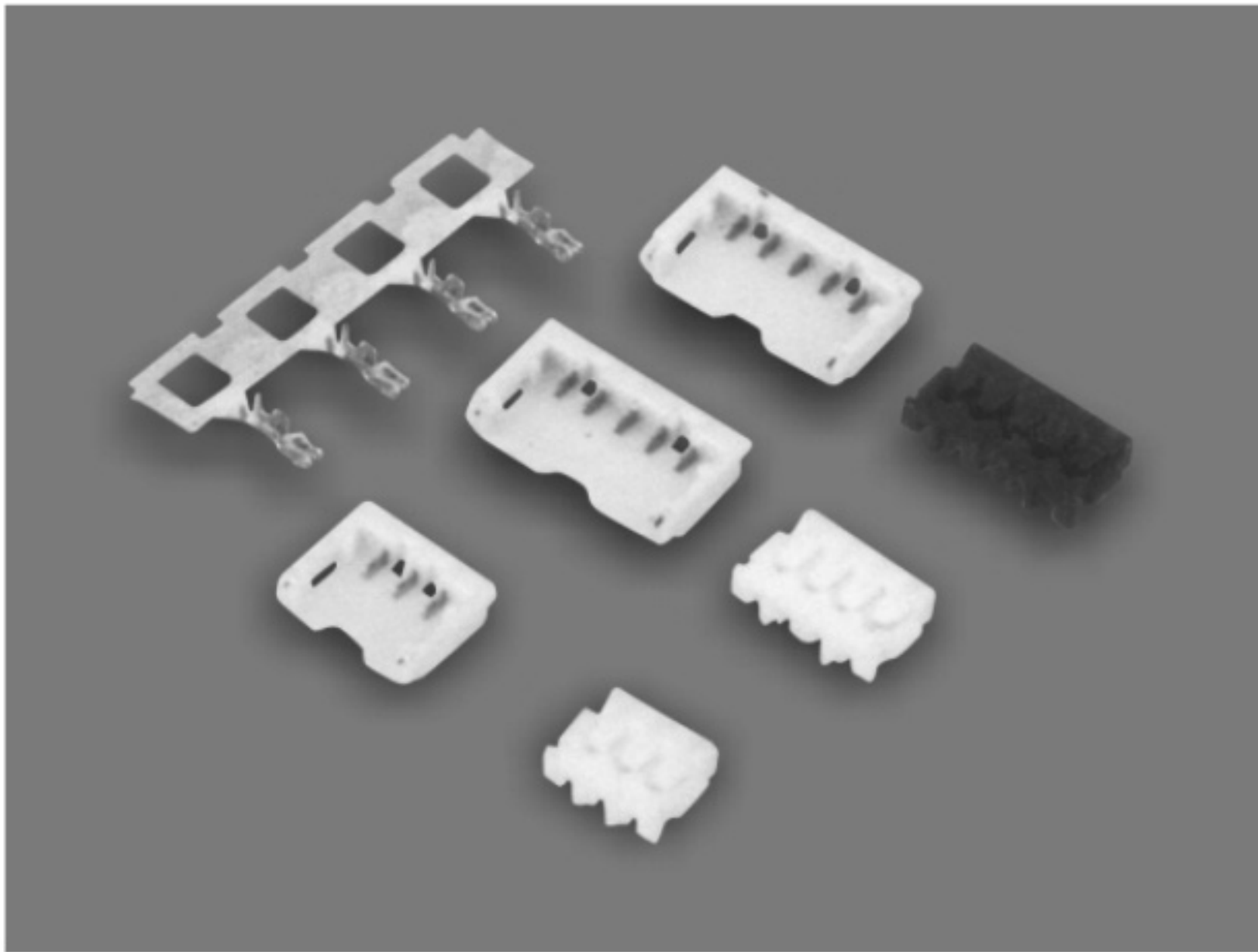

Specifications

Current rating: 2A AC,DC

Voltage rating: 50V AC,DC

Temperature range: -25°C to + 85°C
(including temperature rise)

Contact resistance: 10m Ω Max.

After environmental testing/20m Ω Max.

Insulation resistance: 100M Ω Min.

Withstanding voltage: 500V AC/minute

Applicable Wire: AWG#28~#32

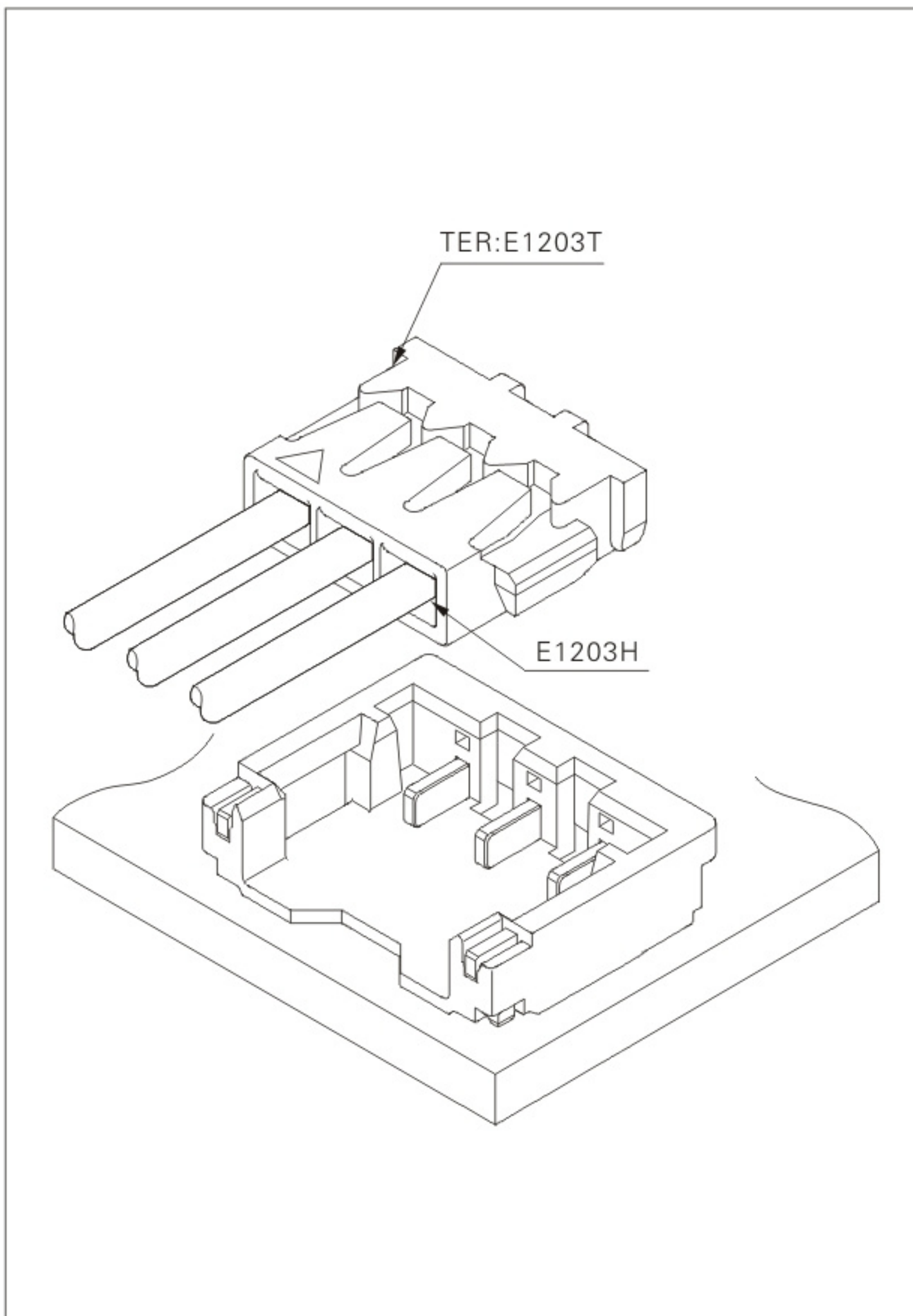

Assembly layout

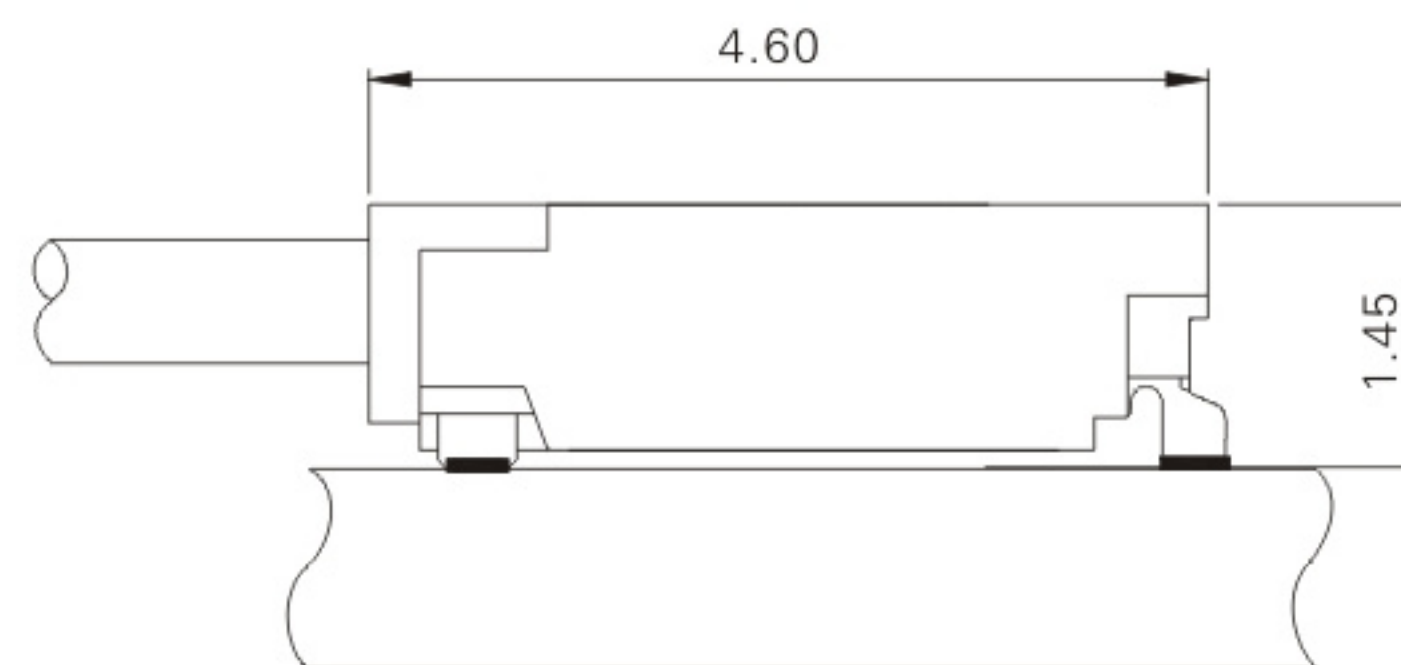

E1203-T (1.20mm pitch crimp terminal)

Reference Informations:

- *Material: Phosphor Bronze/Gold-flash
- *Mates with E1203H series Housing

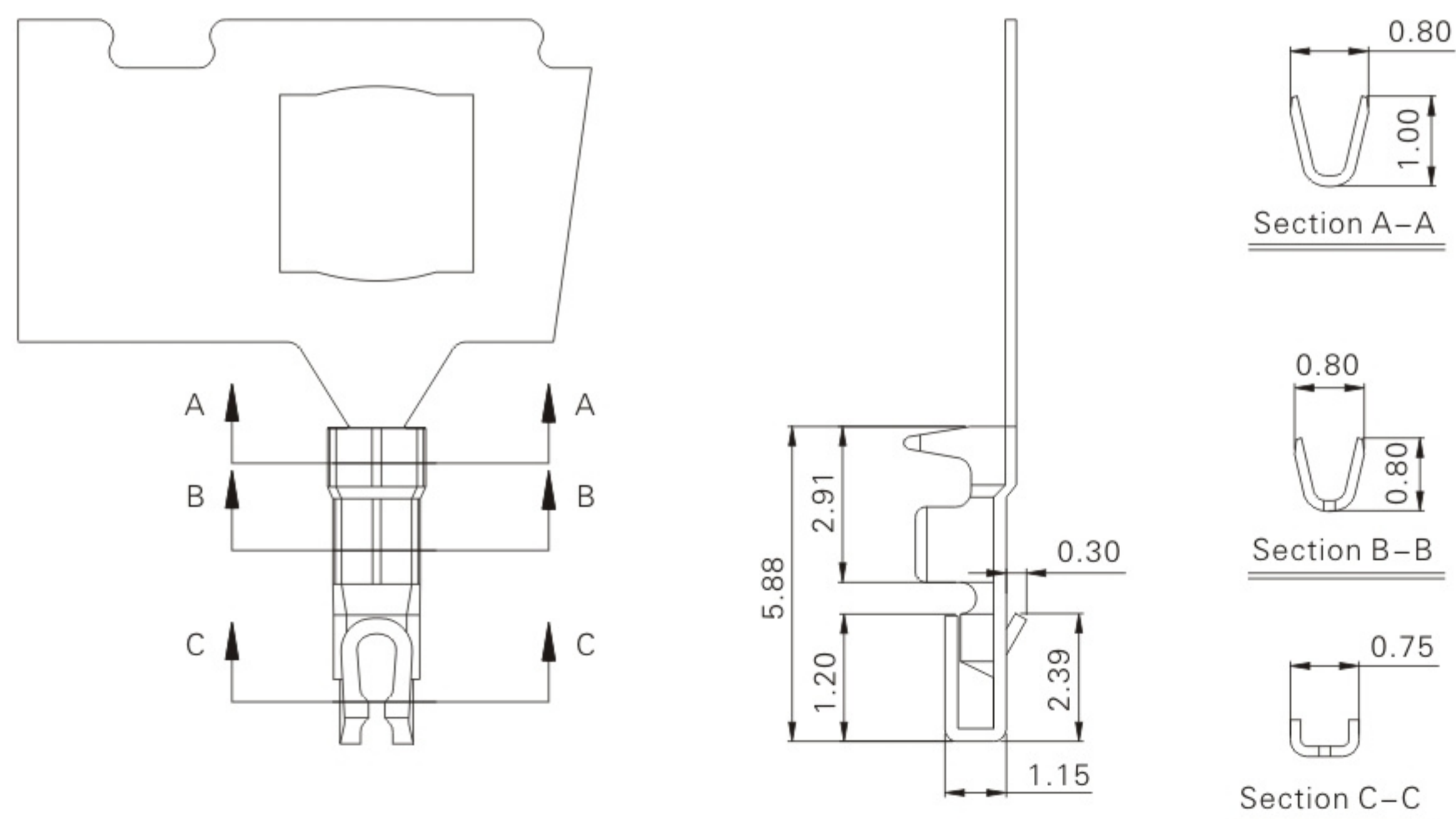

Ordering Information & Specifications

Unit: mm

Part No.	Wire Range	Insulation O.D.	Material	Finish	Qty/reel
E1203P-00	AWG#28-#32	0.38~0.63mm	Phosphor Bronze	Gold-flash	15,000PCS

E1203H-NP (1.20mm pitch crimp housing)

Reference Informations:

- *Material: Housing: E1203H UL94V-0/White or Black
- *Suitable E1203H series Terminal
- *Mates with E1203H series Wafer

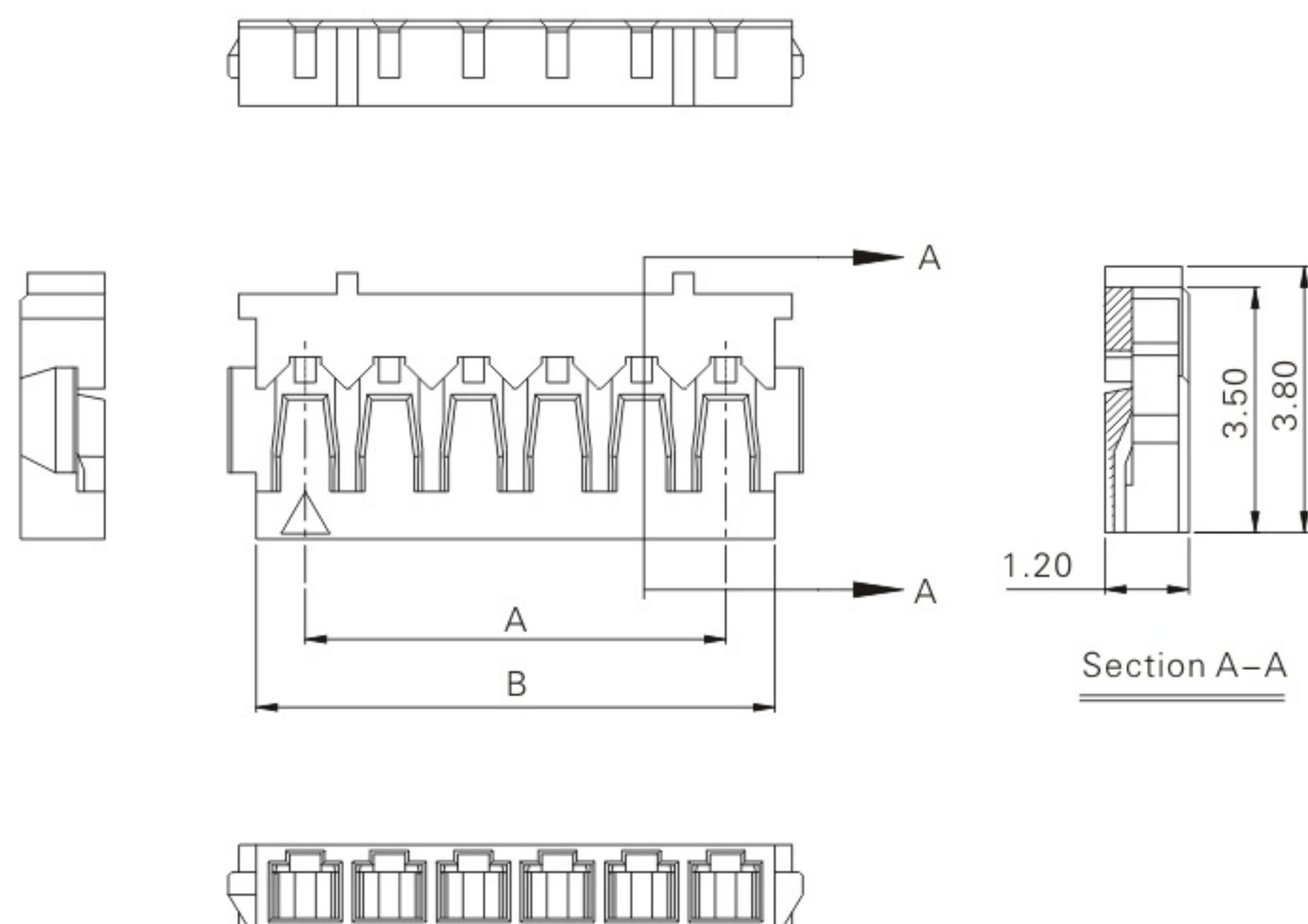
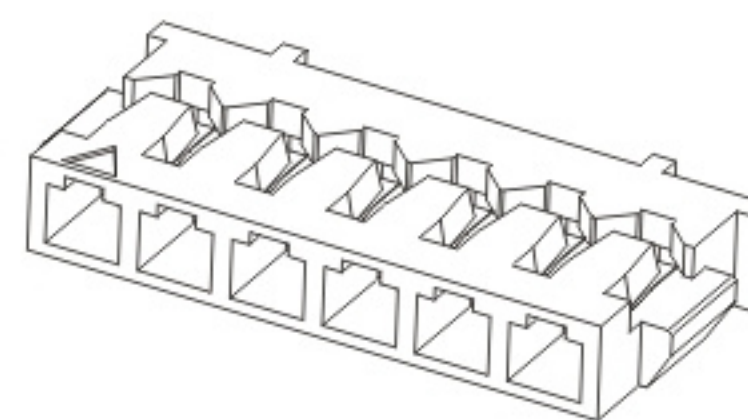

Ordering Information & Dimensions

Circuits	Part No.	DIM.(mm)	
		A	B
01	E1203H-01P	/	1.40
02	E1203H-02P	1.20	2.60
03	E1203H-03P	2.40	3.80
04	E1203H-04P	3.60	5.00
05	E1203H-05P	4.80	6.20
06	E1203H-06P	6.00	7.40
07	E1203H-07P	7.20	8.60
08	E1203H-08P	8.40	9.80
09	E1203H-09P	9.60	11.00
10	E1203H-10P	10.80	12.20
11	E1203H-11P	12.00	13.40
12	E1203H-12P	13.20	14.60
13	E1203H-13P	14.40	15.80
14	E1203H-14P	15.60	17.00
15	E1203H-15P	16.80	18.20