

E2090H SERIES

2.00mm PITCH WIRE TO BOARD CONNECTOR

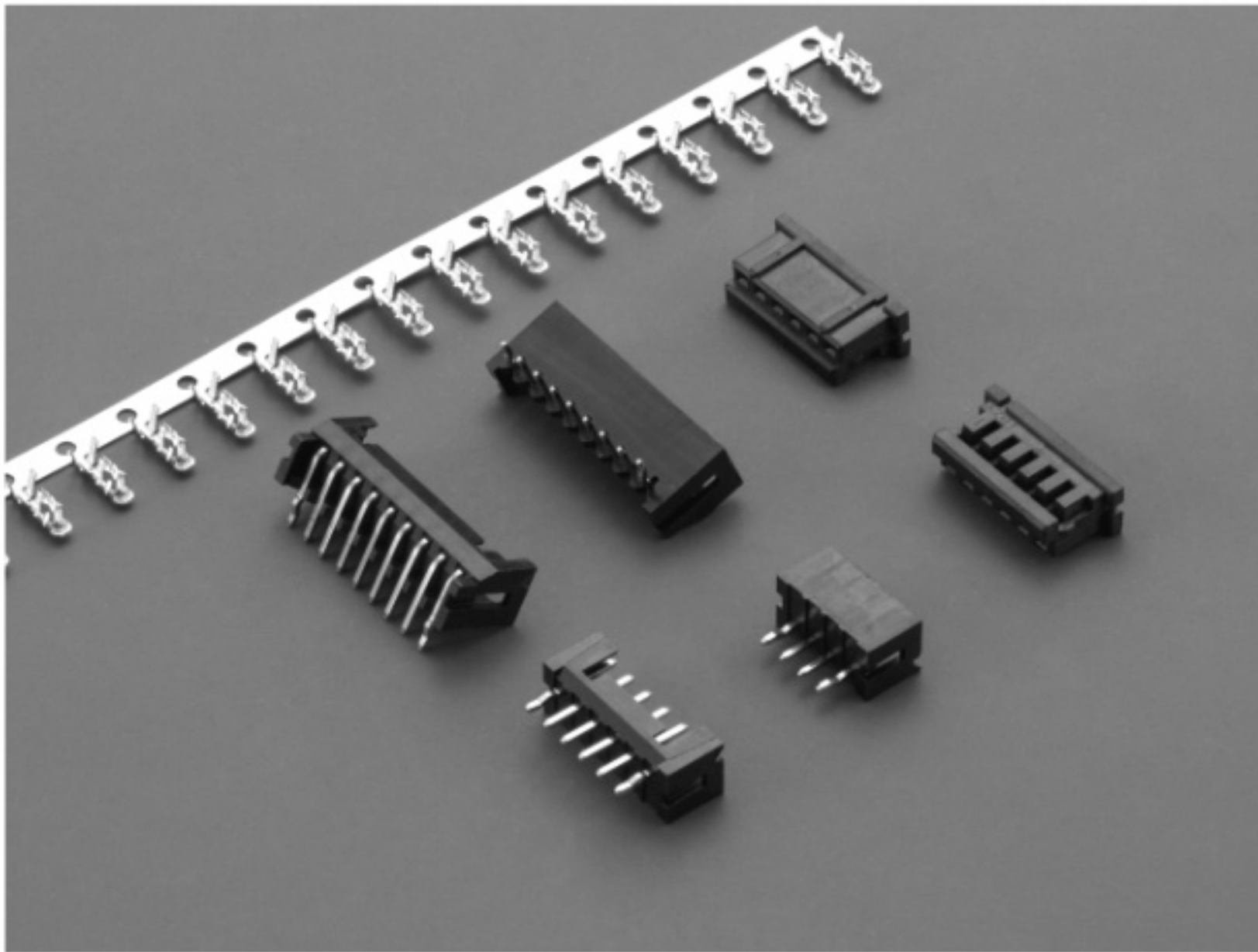

Specifications

Current Rating: 3A AC,DC

Voltage Rating: 250V AC,DC

Temperature Range: -25°C~+85°C

Contact Resistance: 30mΩ Max.

Insulation Resistance: 1000MΩ Min.

Withstanding Voltage: 650V AC/minute

Applicable wire: AWG#22-#28

Assembly layout

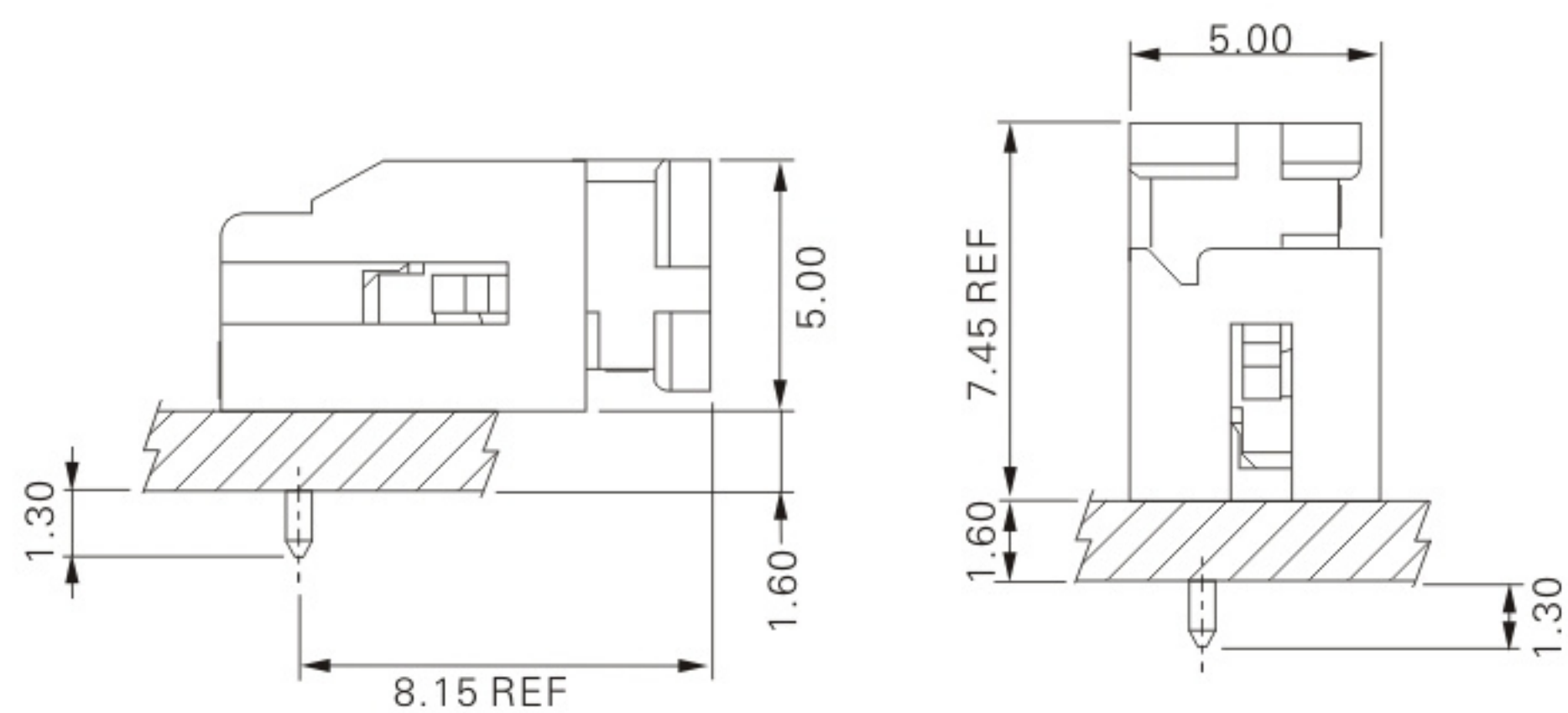
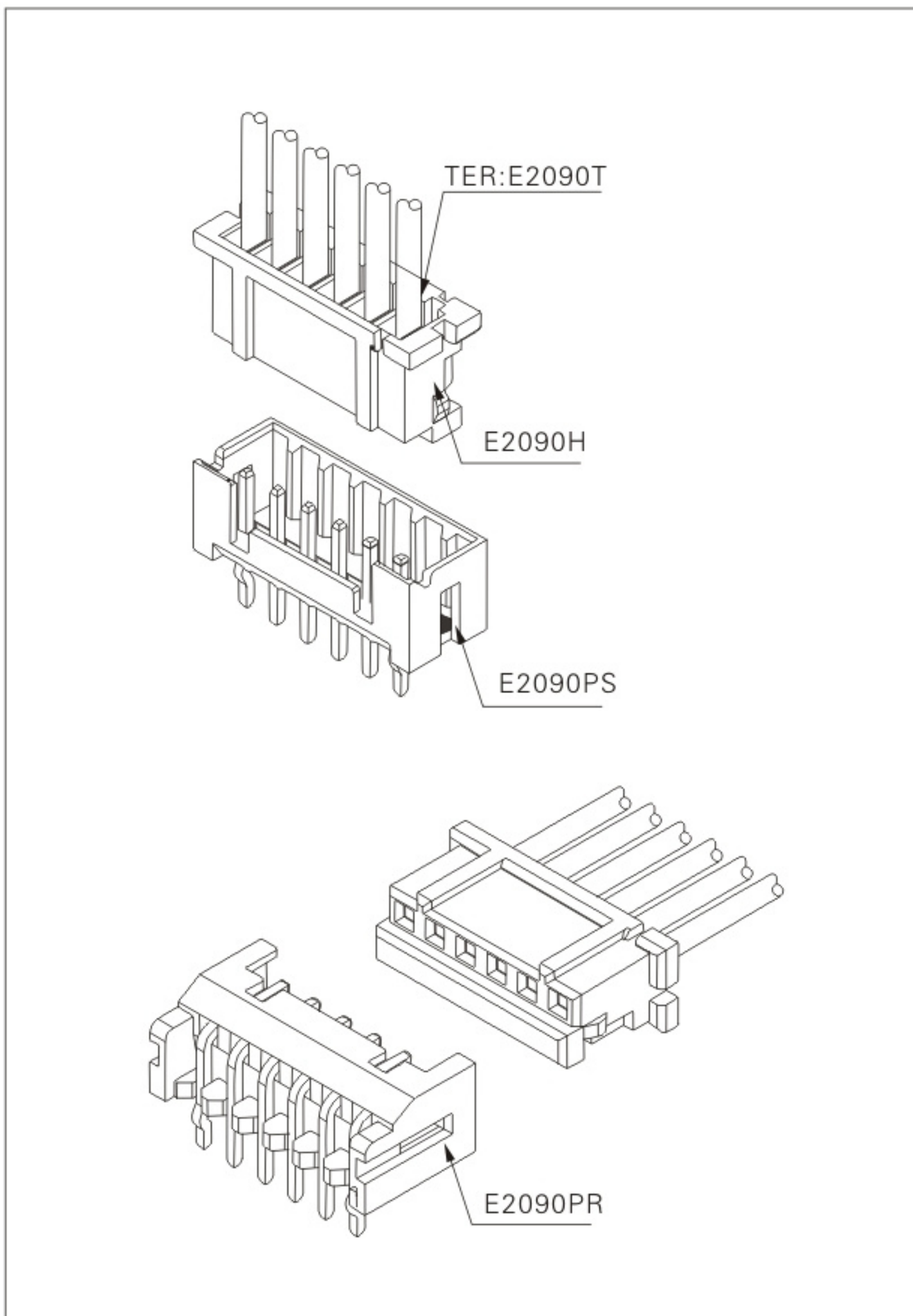

E2090-T (2.00mm pitch crimp terminal)

Reference Informations:

*Used in E2090H series Housing

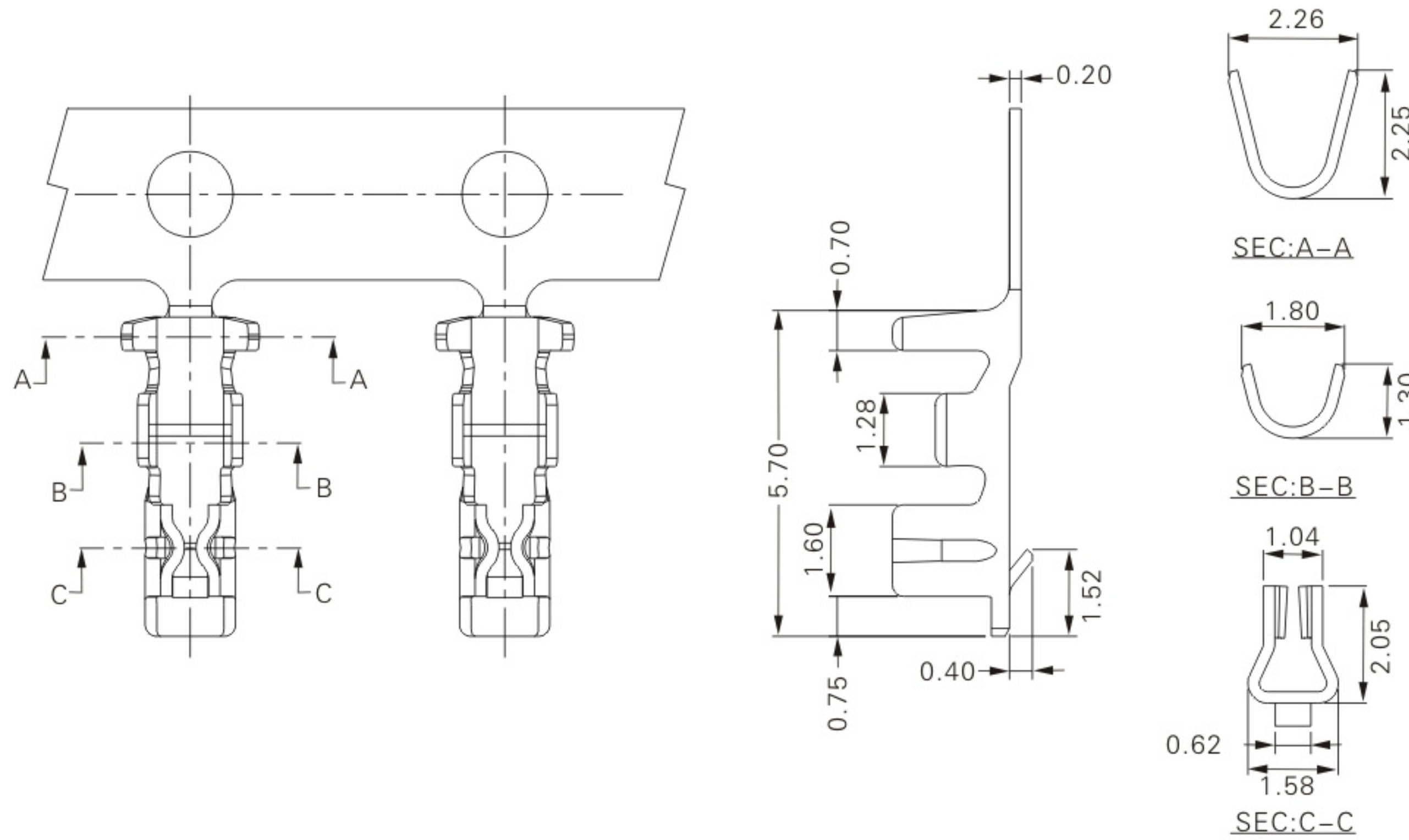

Ordering Information & Specifications

Unit: mm

Part No.	Wire Range	Insulation O.D.	Material	Finish	Qty/reel
E2090P	AWG#22-#28	1.45mm(max)	Phosphor Bronze	Tin-plated	10,000pcs

E2090H-NP (2.00mm pitch crimp housing)

Reference Informations:

*Material:Nylon 66,UL94V-0

*Suitable E2090-T series Terminal

*Mates with E2090PS E2090PR series Wafer

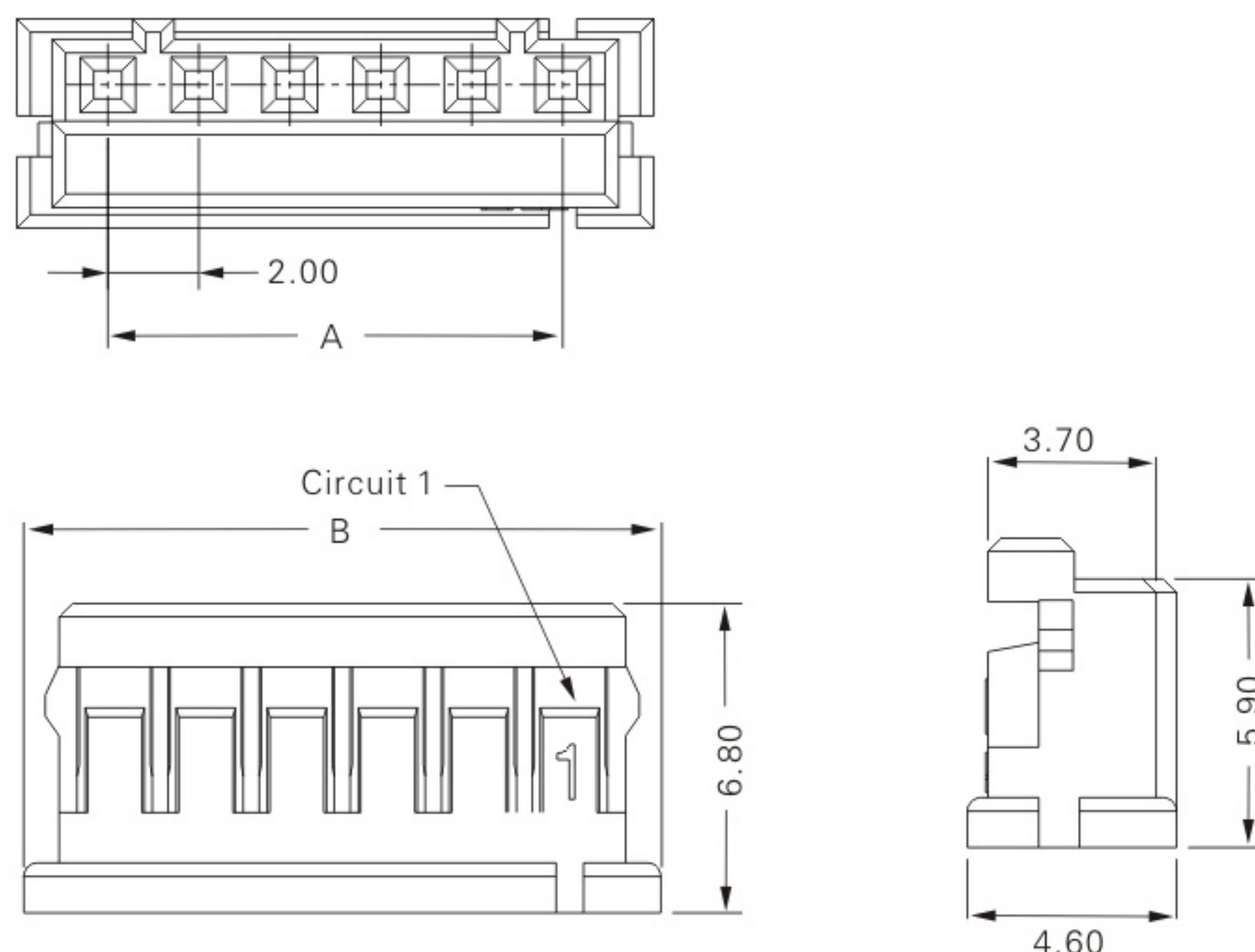
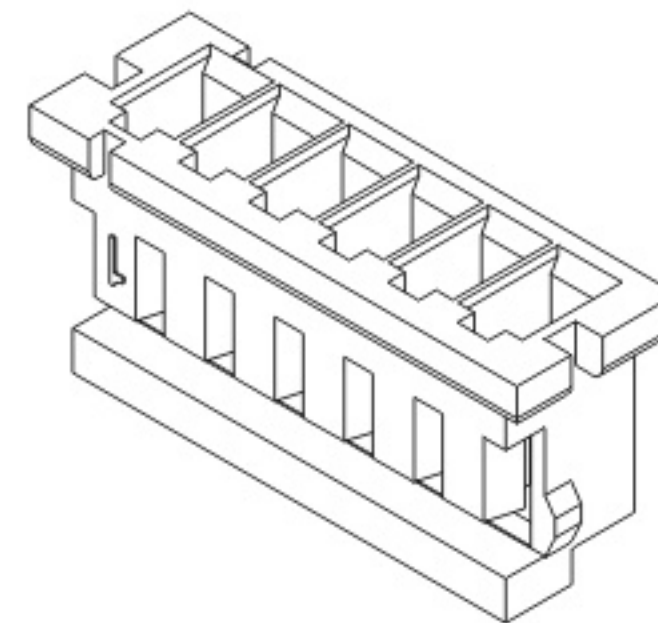

Ordering Information & Dimensions

Circuits	Part No.	DIM.(mm)	
		A	B
02	E2090H-02P	2.00	6.00
03	E2090H-03P	4.00	8.00
04	E2090H-04P	6.00	10.00
05	E2090H-05P	8.00	12.00
06	E2090H-06P	10.00	14.00
07	E2090H-07P	12.00	16.00
08	E2090H-08P	14.00	18.00
09	E2090H-09P	16.00	20.00
10	E2090H-10P	18.00	22.00
11	E2090H-11P	20.00	24.00
12	E2090H-12P	22.00	26.00
13	E2090H-13P	24.00	28.00
14	E2090H-14P	26.00	30.00
15	E2090H-15P	28.00	32.00

E2090PS-NP (2.00mm pitch 180° wafer)

Reference Informations:

*Material:Pin:Brass/ Gold-flash

Wafer:Nylon 6T,UL94V-0

*Mates with E2090H series Housing

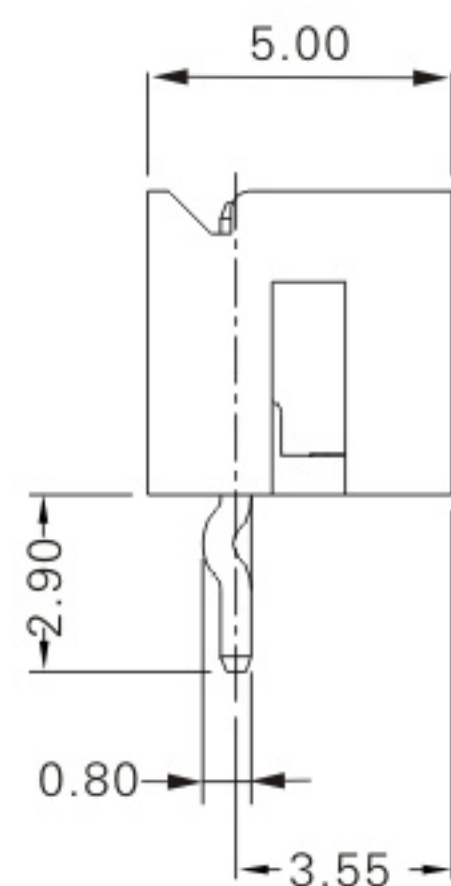
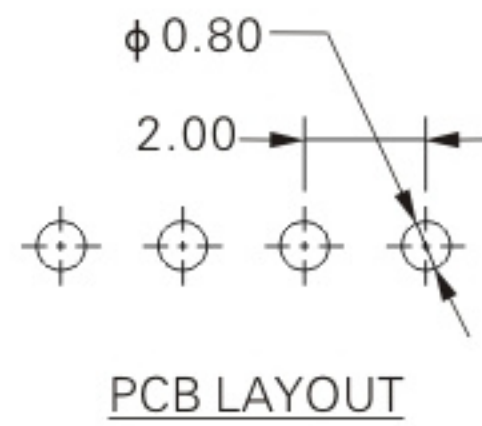
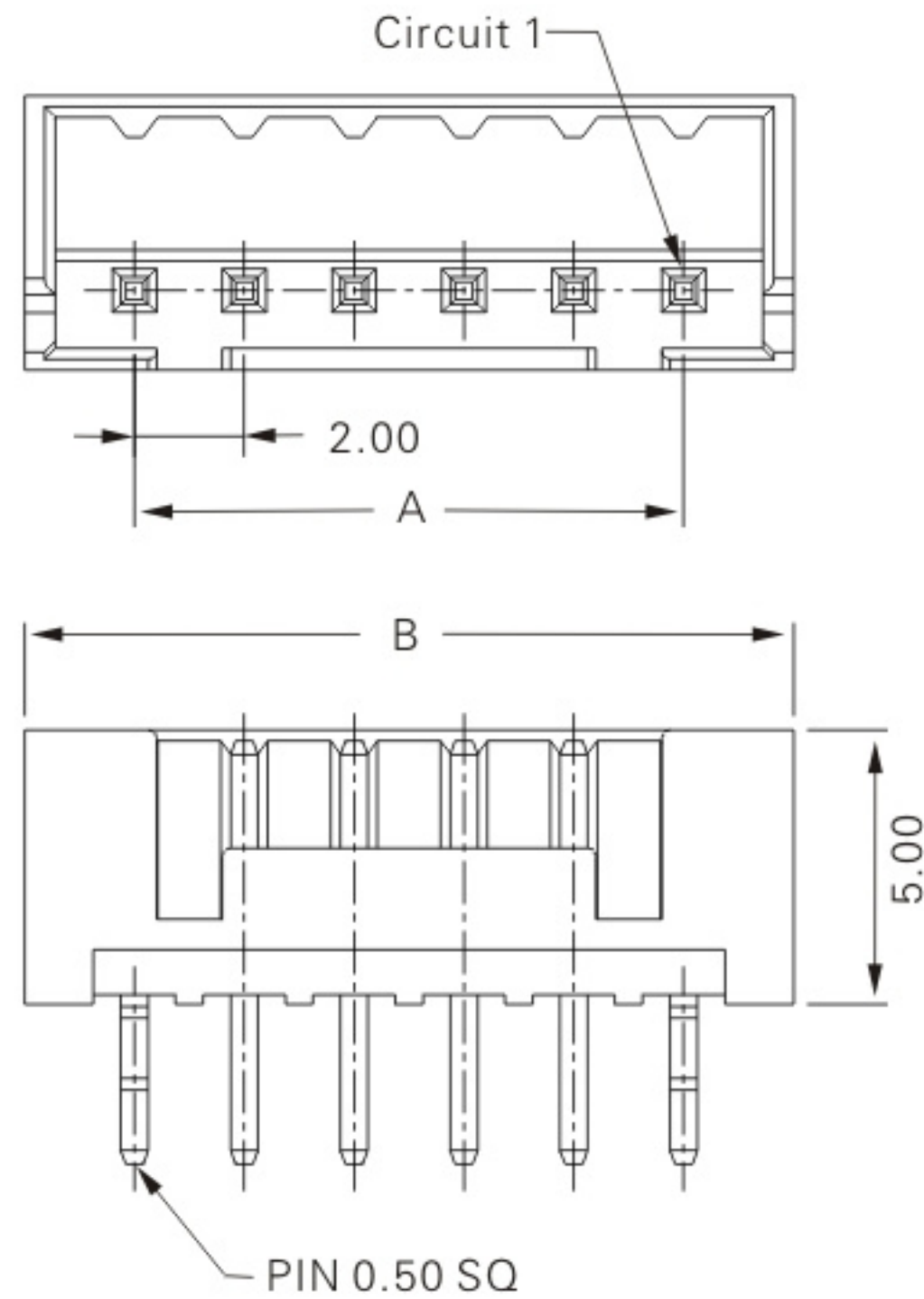
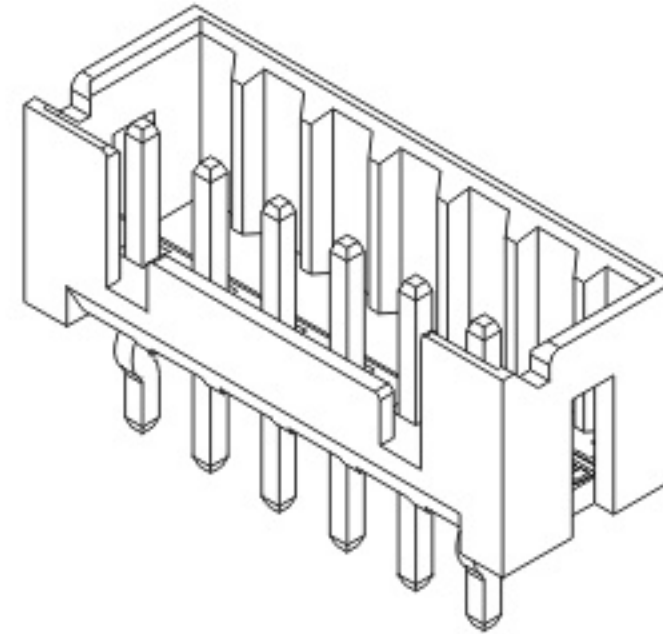

Ordering Information & Dimensions

Circuits	Part No.	DIM.(mm)	
		A	B
02	E2090PS-02P	2.00	6.00
03	E2090PS-03P	4.00	8.00
04	E2090PS-04P	6.00	10.00
05	E2090PS-05P	8.00	12.00
06	E2090PS-06P	10.00	14.00
07	E2090PS-07P	12.00	16.00
08	E2090PS-08P	14.00	18.00
09	E2090PS-09P	16.00	20.00
10	E2090PS-10P	18.00	22.00
11	E2090PS-11P	20.00	24.00
12	E2090PS-12P	22.00	26.00
13	E2090PS-13P	24.00	28.00
14	E2090PS-14P	26.00	30.00
15	E2090PS-15P	28.00	32.00

E2090PR-NP (2.00mm pitch 90° wafer)

Reference Informations:

*Material:Pin:Brass/ Gold-flash

Wafer:Nylon 6T,UL94V-0

*Mates with E2090H series Housing

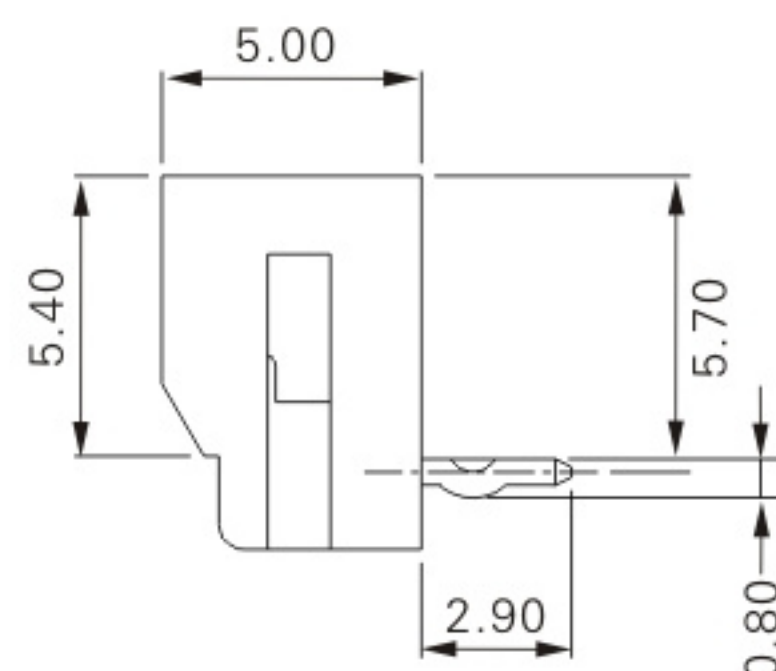
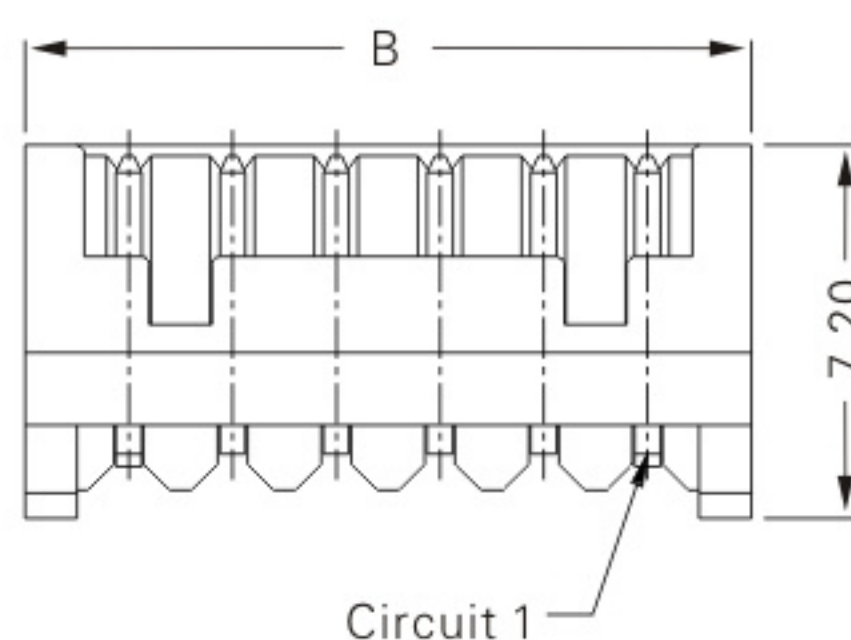
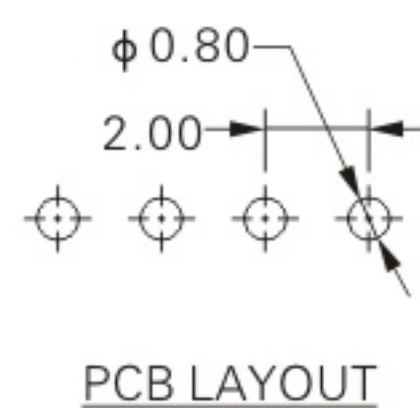
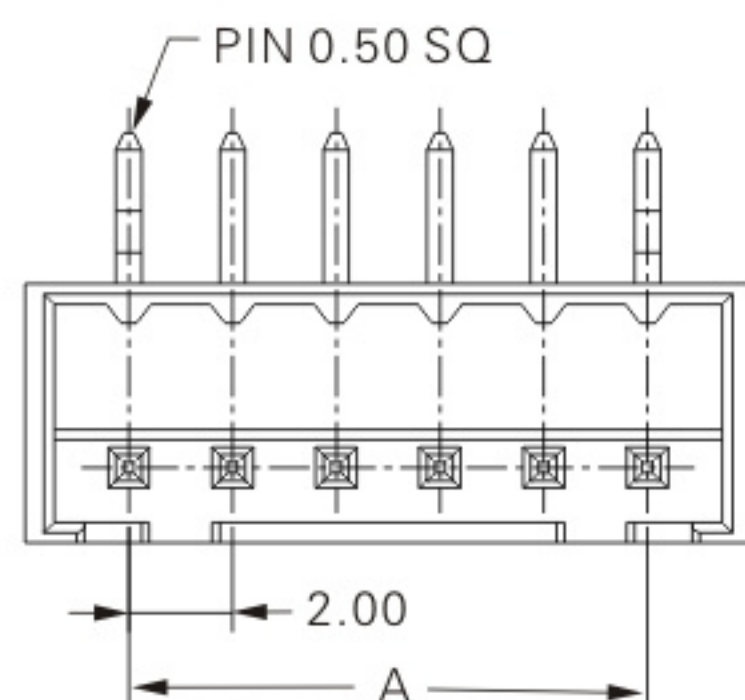
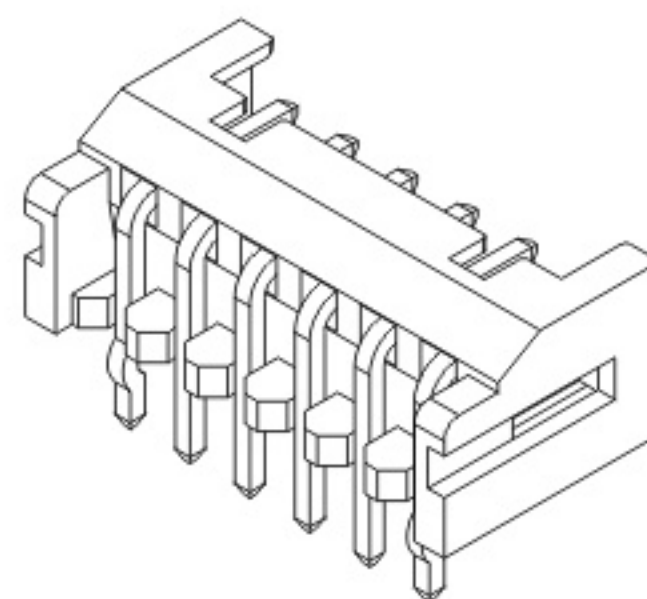

Ordering Information & Dimensions

Circuits	Part No.	DIM.(mm)	
		A	B
02	E2090PR-02P	2.00	6.00
03	E2090PR-03P	4.00	8.00
04	E2090PR-04P	6.00	10.00
05	E2090PR-05P	8.00	12.00
06	E2090PR-06P	10.00	14.00
07	E2090PR-07P	12.00	16.00
08	E2090PR-08P	14.00	18.00
09	E2090PR-09P	16.00	20.00
10	E2090PR-10P	18.00	22.00
11	E2090PR-11P	20.00	24.00
12	E2090PR-12P	22.00	26.00
13	E2090PR-13P	24.00	28.00
14	E2090PR-14P	26.00	30.00
15	E2090PR-15P	28.00	32.00